

INSTALLATION INSTRUCTION

SINGLE PACKAGE AIR CONDITIONERS GAS/ELECTRIC, AIR COOLED

Supersedes: 530.46-N4Z (899)

035-18267-000 (0801)

MODELS DAYA018 THRU 048 MODEL DBYA060 1-1/2 THRU 5 TON (10 SEER)

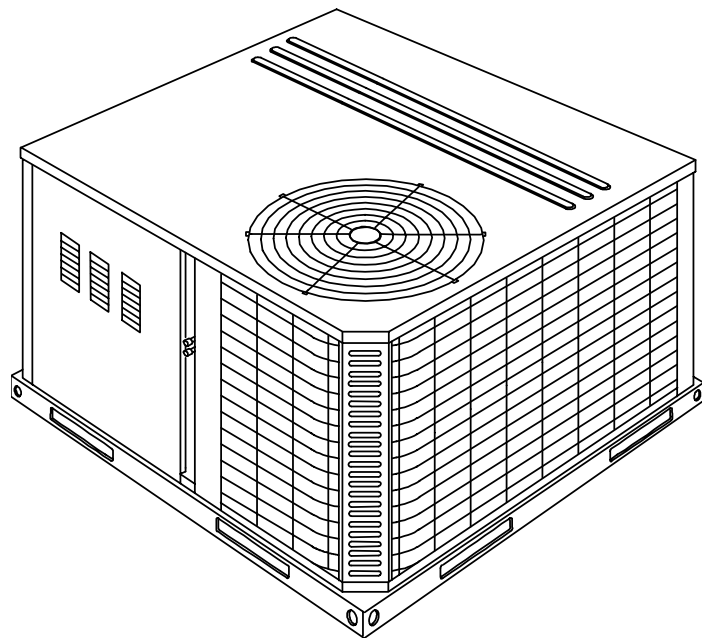

WARNING: If the information in this manual is not followed exactly, a fire or explosion may result causing property damage, personal injury or loss of life.

- Do not store or use gasoline or other flammable vapors and liquids in the vicinity of this or any other appliance.
- **WHAT TO DO IF YOU SMELL GAS**
 - Do not try to light any appliance.
 - Extinguish any open flames.
 - Do not touch any electrical switch; do not use any phone in your building.
 - Immediately call your gas supplier from a neighbor's phone. Follow the gas supplier's instructions.
 - If you cannot reach your gas supplier, call the fire department.

GENERAL

Model DAYA and DBYA units are cooling/heating air conditioners designed for outdoor installation. Only gas piping, electric power and duct connections are required at the point of installation.

The gas-fired heaters have hot surface to pilot ignition. The tubular heat exchangers are aluminized steel.

This appliance is not to be used for temporary heating of buildings or structures under construction.

INSPECTION

As soon as a unit is received, it should be inspected for possible damage during transit. If damage is evident, the extent of the damage should be noted on the carrier's freight bill. A separate request for inspection by the carrier's agent should be made in writing. Refer to Form 50.15-NM for additional information.

REPLACEMENT PARTS

- Refer to Replacement Parts, Form 530.46-RP1Y, RP2Y, RP3Y, RP4Y and RP5Y for Key Replacement Parts.

All forms referenced in this instruction may be ordered from:

**Publications Distribution Center
Unitary Products Group
P.O. Box 1592, York, Pa. 17405**

APPROVALS

Design certified by CGA and AGA listed as follows:

1. For use as a forced air furnace with cooling unit.
2. For outdoor installation only.
3. For installation directly on combustible flooring or, in U.S., on wood flooring or Class A; B; C roof covering material.
4. For installation on combustible material.
5. For use with natural gas and/or propane (LP) gas.

CAUTION

THIS PRODUCT MUST BE INSTALLED IN STRICT COMPLIANCE WITH THE ENCLOSED INSTALLATION INSTRUCTIONS AND ANY APPLICABLE LOCAL, STATE, AND NATIONAL CODES INCLUDING, BUT NOT LIMITED TO, BUILDING, ELECTRICAL, AND MECHANICAL CODES.

WARNING

INCORRECT INSTALLATION MAY CREATE A CONDITION WHERE THE OPERATION OF THE PRODUCT COULD CAUSE PERSONAL INJURY OR PROPERTY DAMAGE.

Installer should pay particular attention to the words: *NOTE*, *CAUTION* and *WARNING*. *Notes* are intended to clarify or make the installation easier. *Cautions* are given to prevent equipment damage. *Warnings* are given to alert installer that personal injury and/or equipment damage may result if installation procedure is not handled properly.

TABLE OF CONTENTS

General..... 1
 Inspection 1
 Replacement Parts 1
 Approvals..... 1
 Nomenclature 2

INSTALLATION

Limitations..... 3
 Location 3
 Rigging and Handling 3
 Clearances 3
 Ductwork..... 3
 Roof Curb 4
 Filters 4
 Condensate Drain..... 4
 Service Access 4
 Thermostat..... 4
 Power and Control Wiring..... 4
 Compressors 4
 Combustion Discharge 5
 Gas Piping 5
 Gas Connection 5
 Flue Vent Hoods 6

SEQUENCE OF OPERATION

Heating 9
 Cooling 9
 Circulating Fan..... 9

START-UP

Pre-start Check List 9
 Operating Instructions..... 9
 To Turn Off Gas To Unit 9
 Post-Start Check List (Gas) 9
 Manifold Gas Pressure Adjustment 10
 Burner Instructions..... 10
 Hot Surface Pilot Instructions 10
 Adjustment of Temperature Rise 11
 Checking Gas Input 11
 Secure Owner's Approval..... 11

MAINTENANCE

Normal Maintenance..... 12
 Cleaning Flue Passages and Heating Elements 12

TROUBLESHOOTING

Troubleshooting Chart..... 15

TABLES

No.	Description	Page
1	Units Application Data	3
2	Natural Gas Application Data	5
3	LP Gas Application Data.....	5
4	Natural Gas Pipe Sizing.....	5
5	LP Gas Pipe Sizing.....	5
6	Physical Data	6
7	Unit Weights.....	7
8	Electrical Data.....	7
9	Gas Rate - Cubic Feet Per Hour	11
10	Superheat Charging Table, 018	13
11	Superheat Charging Table, 024	13
12	Superheat Charging Table, 030	13
13	Superheat Charging Table, 036	13
14	Superheat Charging Table, 042	14
15	Superheat Charging Table, 048	14
16	Superheat Charging Table, 060	14

FIGURES

No.	Description	Page
1	Field Wiring Diagram.....	4
2	External Supply Connection	5
3	Flue Vent Hood.....	6
4	Center of Gravity	7
5	Dimensions and Clearances	8
6	Gas Valves.....	10
7	Proper Flame Adjustment.....	10
8	Ignitor and Flame Sensor Assembly	10
9	Typical Wiring Diagram, (208/230-1-60)	16
10	Typical Wiring Diagram, (208/230-3-60)	16
11	Typical Wiring Diagram, (460-3-60)	17
12	Typical Wiring Diagram, (575-3-60)	17
13	Wiring Diagram, Detail "B"	18

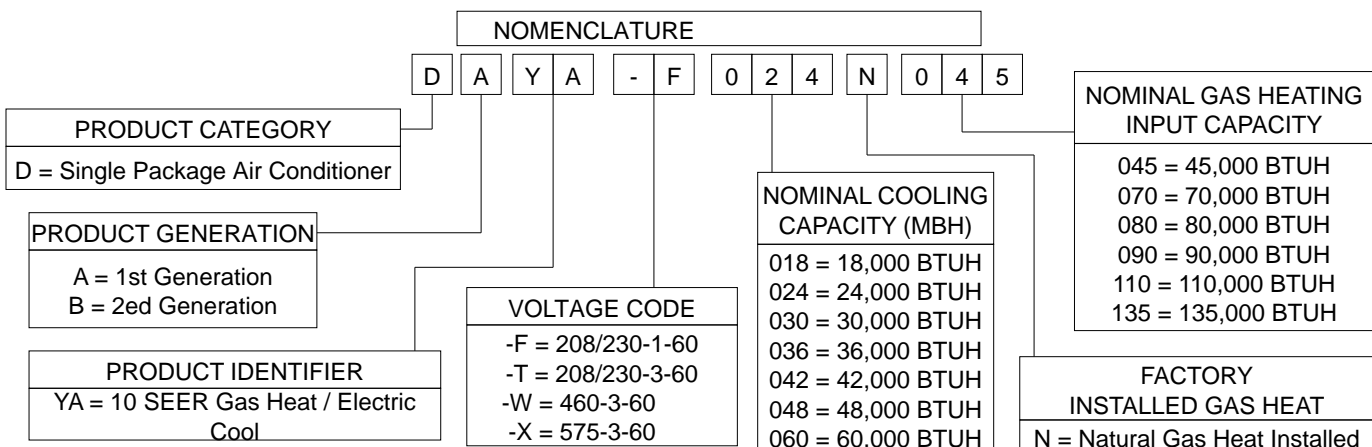

INSTALLATION

Not suitable for use with conventional venting systems.

LIMITATIONS

These units must be installed in accordance with the following national and local safety codes.

1. National Electrical Code ANSI/NFPA No. 70 or Canadian Electrical Code Part 1, C22.1 (latest editions).
2. National Fuel Gas Code Z223.1 or CAN/CGA B149.1 or .2 Installation Code.
3. Local gas utility requirements.
4. Local plumbing and waste water codes and other applicable local codes.

Refer to Table 1 for unit application data and to Table 2 for gas heat application data.

If components are to be added to a unit to meet local codes, they are to be installed at the dealer's and/or the customer's expense.

Size of unit for proposed installation should be based on heat

TABLE 1 - UNIT APPLICATION DATA

Voltage Variation Min. / Max. ¹	208/230V ³	187 / 253 ³
	460V	414 / 504
	575V	518 / 630
Wet Bulb Temperature (°F) of Air on Evaporator Coil, Min. / Max.		57 / 72
Dry Bulb Temperature (°F) of Air on Condenser Coil, Min. ² / Max.		45 / 120

¹ Utilization range "A" in accordance with ARI Standard 110.

² A low ambient accessory is available for operation down to 0°F

³ "T1" transformer primary tap must be moved from the 230 volt connection to the 208 volt connection for low voltage applications of 208 volt and below.

loss/heat gain calculations made in accordance with industry recognized procedures identified by the Air Conditioning Contractors of America.

LOCATION

Use the following guidelines to select a suitable location for these units.

1. Unit is designed for outdoor installation only.
2. Condenser must have an unlimited supply of air. Where a choice of location is possible, position unit on either north or east side of building.

WARNING: Excessive exposure of this furnace to contaminated combustion air may result equipment damage or personal injury. Typical contaminants include: permanent wave solutions, chlorinated waxes and cleaners, chlorine based swimming pool chemicals, water softening chemicals, carbon tetrachloride, Halogen type refrigerants, cleaning solvents (e.g. perchloroethylene), printing inks, paint removers, varnishes, hydrochloric acid, cements and glues, antistatic fabric softeners for clothes dryers, masonry acid washing materials.

3. For ground level installation, a level pad or slab should be used. The thickness and size of the pad or slab used should meet local codes and unit weight. Do not tie the slab to the building foundation.
4. For roof top installation, be sure the structure will support the weight of the unit plus any field installed components. Unit must be installed on a level roof curb or appropriate an-

gle iron frame providing adequate support under the compressor/condenser section.

5. Maintain level tolerance of unit to 1/8" maximum.

RIGGING OR HANDLING

Care must be exercised when moving the unit. Do not remove any packaging until the unit is near the place of installation. Rig unit with slings placed under the unit. Spreader bars of sufficient length should be used across the top of the unit.

BEFORE LIFTING A UNIT, MAKE SURE THAT ITS WEIGHT IS DISTRIBUTED EQUALLY ON THE CABLES SO THAT IT WILL LIFT EVENLY.

Units may also be moved or lifted with a fork-lift. Slotted openings in the skid are provided for this purpose. Forks must pass completely through the base.

Refer to Table 7 for unit weights and to Figure 4 for approximate center of gravity.

CLEARANCES

All units require certain clearances for proper operation and service. Refer to Figure 5 for the clearances required for combustion, construction, servicing and proper unit operation.

WARNING: Do not permit overhanging structures or shrubs to obstruct the condenser air discharge, combustion air inlet or vent outlet.

DUCT WORK

These units are adaptable to downflow use as well as rear supply and return air duct openings. To convert to downflow, use the following steps:

1. Remove the duct covers found in the bottom return and supply air duct openings. There are four (4) screws securing each duct cover (save these screws to use later).
2. Install the duct covers, removed in step one, to the rear supply and return air duct openings. Secure with the four (4) screws used in step one.
3. Seal the duct covers with silicone caulk.

Duct work should be designed and sized according to the methods of the Air Conditioning Contractors of America (ACCA), as set forth in their Manual D.

A closed return duct system shall be used. This shall not preclude use of economizers or ventilation air intake. Flexible joints may be used in the supply and return duct work to minimize the transmission of noise.

CAUTION: When fastening duct work to the side duct flanges on the unit, insert the screws through the duct flanges only. DO NOT insert the screws through the casing. Outdoor duct work must be insulated and waterproofed.

NOTE: Be sure to note supply and return openings.

Refer to Figure 5 for information concerning rear and bottom supply and return air duct openings.

ROOF CURB

On applications when a roof curb is used, the unit must be positioned on the curb so the front of the unit is tight against the curb.

FILTERS

Single phase units are shipped without a filter and is the responsibility of the installer to secure a filter **in the return air ductwork or install a Filter/Frame Kit** (1FF0110 for the DAYA018 thru DAYA042 and 1FF0112 for the DAYA048 and DBYA060).

A filter rack and filters are standard on three phase units.

NOTE: Filters on the DAYA048 and DBYA060 units require the use of a 5/16" nut driver for removal.

Filters must always be used and must be kept clean. When filters become dirt laden, insufficient air will be delivered by the blower, decreasing your units efficiency and increasing operating costs and wear-and-tear on the unit and controls.

Filters should be checked monthly especially since this unit is used for both heating and cooling.

CONDENSATE DRAIN

A condensate trap is recommended to be installed in the condensate drain. The plumbing must conform to local codes. Use a sealing compound on male pipe threads. Install the condensate drain line (3/4" NPTF) to spill into an open drain.

SERVICE ACCESS

Access to all serviceable components is provided by the following removable panels:

- Blower compartment

- Gas control/electrical service access

Refer to Figure 5 for location of these access panels and minimum clearances.

THERMOSTAT

The room thermostat should be located on an inside wall approximately 56" above the floor where it will not be subject to drafts, sun exposure or heat from electrical fixtures or appliances. Follow manufacturer's instructions enclosed with the thermostat for general installation procedure. Four color coded insulated wires (minimum #18 AWG) should be used to connect thermostat to unit. See Figure 1.

POWER AND CONTROL WIRING

Field wiring to the unit must conform to provisions of the current N.E.C. ANSI/NFPA No. 70 or C.E.C. and/or local ordinances. The unit must be electrically grounded in accordance with local codes or, in their absence, with the N.E.C./C.E.C. Voltage tolerances which must be maintained at the compressor terminals during starting and running conditions are indicated on the unit Rating Plate and Table 8.

The wiring entering the cabinet must be provided with mechanical strain relief.

A fused disconnect switch should be field provided for the unit. If any of the wire supplied with the unit must be replaced, replacement wire must be of the type shown on the wiring diagram.

Electrical line must be sized properly to carry the load. Each unit must be wired with a separate branch circuit fed directly from the meter panel and properly fused.

Refer to Figure 1 for typical field wiring and to the appropriate unit wiring diagram for control circuit and power wiring information.

COMPRESSORS

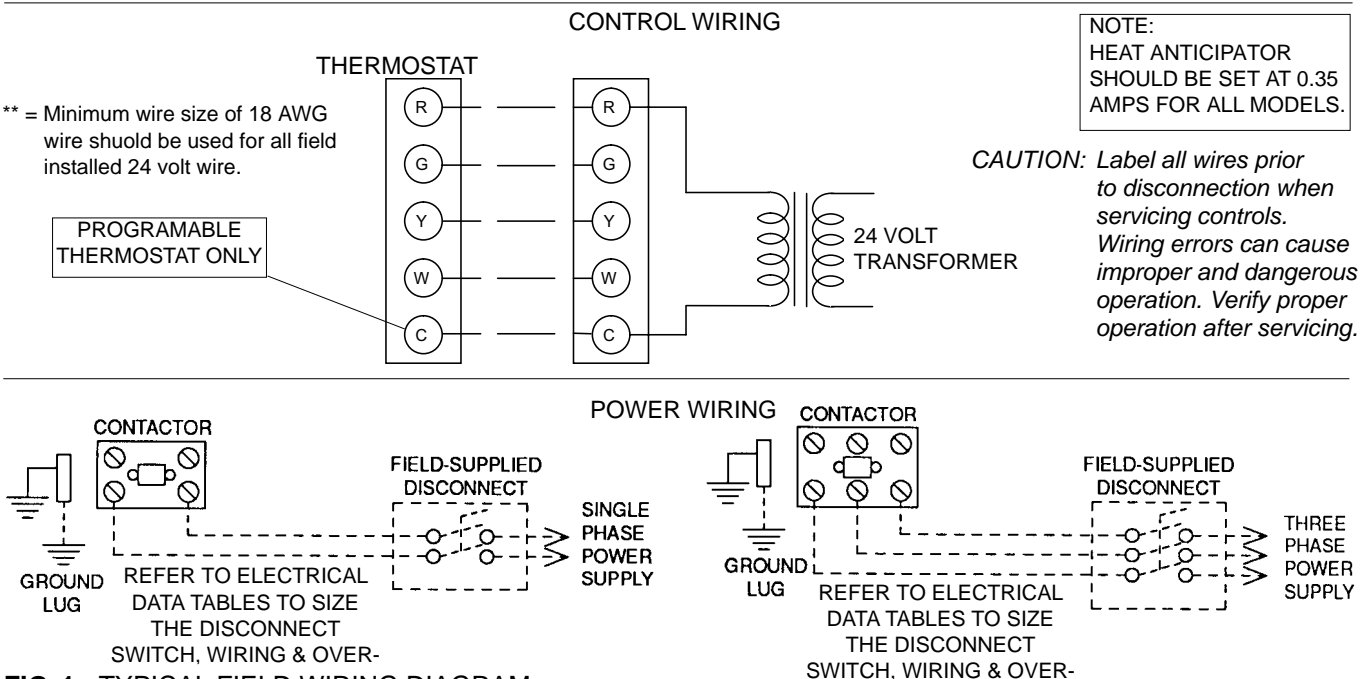

FIG. 1 - TYPICAL FIELD WIRING DIAGRAM

Units are shipped with compressor mountings factory-adjusted and ready for operation.

CAUTION: Do Not loosen compressor mounting bolts.

Scroll compressors operate in one direction only. If a three phase scroll compressor is experiencing:

- Low amperage draw
- Similar discharge and suction pressures
- Increased noise level

TABLE 2 - NATURAL GAS APPLICATION DATA

Input Capacity (Mbh) ³	Output Capacity (Mbh)	Available On Models	Gas Rate ¹ Ft. ³ /Hr.	Number of Burners	Temp. Rise °F At Full Input ²	
					Min.	Max.
45	36	1½, 2, 2½, 3 & 3½ TON	70	2	25	55
70	56	2 & 2½ TON	65	3	30	60
		3 & 3½ TON	65	3	25	55
90	72	3 & 3½ TON	84	4	30	60
80	64	4 & 5 TON	74	3	25	55
108	86	4 & 5 TON	100	4	30	60
135	108	4 & 5 TON	126	5	35	65

1 Based on 1075 BTU/Ft.³.
 2 The air flow must be adjusted to obtain a temperature rise within the range shown. Continuous return air temperatures should not be below 55°F.
 3 Heating capacity valid for elevations up to 2000 feet above sea level. For elevations above 2000 feet, rated capacity should be reduced by 4% for each 1000 feet above sea level.

TABLE 3 - PROPANE (LP) GAS APPLICATION DATA

Input Capacity (Mbh) ³	Output Capacity (Mbh)	Available On Models	Gas Rate ¹ Ft. ³ /Hr.	Number of Burners	Temp. Rise °F At Full Input ²	
					Min.	Max.
45	36	1½, 2, 2½, 3 & 3½ TON	70	2	25	55
70	56	2 & 2½ TON	28	3	30	60
		3 & 3½ TON	28	3	25	55
90	72	3 & 3½ TON	36	4	30	60
80	64	4 & 5 TON	32	3	25	55
108	86	4 & 5 TON	43	4	30	60
135	108	4 & 5 TON	54	5	35	65

1 Based on 2500 BTU/Ft.³.
 2 The air flow must be adjusted to obtain a temperature rise within the range shown. Continuous return air temperatures should not be below 55°F.
 3 Heating capacity valid for elevations up to 2000 feet above sea level. For elevations above 2000 feet, rated capacity should be reduced by 4% for each 1000 feet above sea level.
 4 Propane applications are accomplished by field installation of a Propane Conversion Accessory, Model 1NP0805 for 1.5 thru 3.5 ton units and Model 1NP0806 for 4 and 5 ton units.

TABLE 4 - NATURAL GAS PIPE SIZING CHART

Length in Feet	Nominal Inches Iron Pipe Size			
	1/2 in.	3/4 in.	1 in.	1-1/4 in.
10	132	278	520	1,050
20	92	190	350	730
30	73	152	285	590
40	63	130	245	500
50	56	115	215	440
60	50	105	195	400
70	46	96	180	370
80	43	90	170	350
90	40	84	160	320
100	38	79	150	305

Maximum Capacity of Pipe in Cubic Feet of Gas Per Hour (Based Upon A Pressure Drop of 0.3 Inch Water Column and 0.6 Specific Gravity Gas).

then the compressor is operating in reverse. To correct this condition, switch any two (2) line voltage leads at the contactor. Please note, single phase scroll compressor will start and run in one direction only. The reverse operation is not a concern.

COMBUSTION DISCHARGE GAS PIPING

Proper sizing of gas piping depends on the cubic feet per hour of gas flow required, specific gravity of the gas and the length of run. "National Fuel Gas Code" Z223.1 or CAN/CGA B149.1 or .2 should be followed in all cases unless superseded by local codes or gas company requirements. Refer to Tables 4 and 5.

The heating value of the gas may differ with locality. The value should be checked with the local gas utility.

NOTE: There may be a local gas utility requirement specifying a minimum diameter for gas piping. All units require a 1/2 inch pipe connection at the gas valve.

GAS CONNECTION

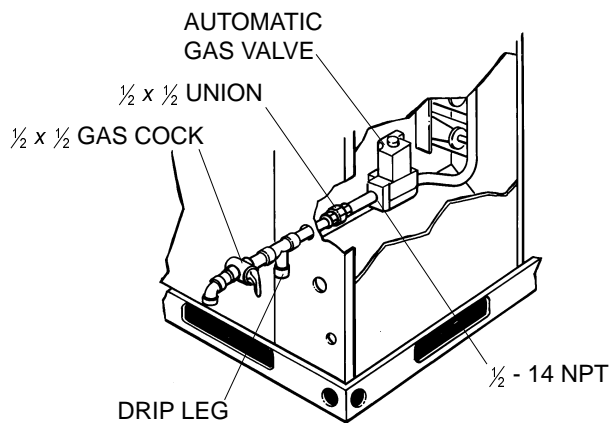

FIG. 2 - EXTERNAL SUPPLY CONNECTION EXTERNAL SHUT-OFF

The gas supply line can be routed through the hole located on the left side of the unit. Refer to Figure 5 to locate these access openings. Typical supply piping arrangements are shown in Figure 2.

Gas piping recommendations:

TABLE 5 - PROPANE (LP) GAS PIPE SIZING CHART

Length in Feet	Nominal Inches Iron Pipe Size			
	1/2 in.	3/4 in.	1 in.	1-1/4 in.
10	275	567	1,071	2,205
20	189	393	732	1,496
30	152	315	590	1,212
40	129	267	504	1,039
50	114	237	448	913
60	103	217	409	834
70	96	196	378	771
80	89	185	346	724
90	83	173	322	677
100	78	162	307	630

Maximum Capacity of Pipe in Thousands of BTU Per Hour (Based Upon A Pressure Drop of 0.5 Inch Water Column).

1. A drip leg and a ground joint union must be installed in the gas piping.
2. When required by local codes, a manual shut-off valve may have to be installed outside of the unit.
3. Use wrought iron or steel pipe for all gas lines. Pipe dope should be applied sparingly to male threads only.

CAUTION: If flexible stainless steel tubing is allowed by the authority having jurisdiction, wrought iron or steel pipe must be installed at the gas valve and extend a minimum of two (2) inches outside of the unit casing.

WARNING: Natural gas may contain some propane. Propane, being an excellent solvent, will quickly dissolve white lead or most standard commercial compounds. Therefore, a special pipe dope must be applied when wrought iron or steel pipe is used. Shellac base compounds such as Gaskolac or Stalastic, and compounds such as Rectorseal #5, Clyde's or John Crane may be used.

4. All piping should be cleaned of dirt and scale by hammering on the outside of the pipe and blowing out the loose dirt and scale. Before initial start-up, be sure that all of the gas lines external to the unit have been purged of air.
5. The gas supply should be a separate line and installed in accordance with all safety codes as prescribed under "Limitations". After the gas connections have been completed, open the main shut-off valve admitting normal gas pressure to the mains. Check all joints for leaks with soap solution or other material suitable for the purpose. NEVER USE A FLAME.
6. The furnace and its individual manual shut-off valve must be disconnected from the gas supply piping system during any pressure testing of that system at test pressures in excess of 1/2 psig (3.48 kPa).

The furnace must be isolated from the gas supply piping system by closing its individual manual shut-off valve during any pressure testing of the gas supply piping system at test pressures equal to or less than 1/2 psig (3.48 kPa).

FLUE VENT HOOD

The flue vent hood with screen is not shipped attached. This hood

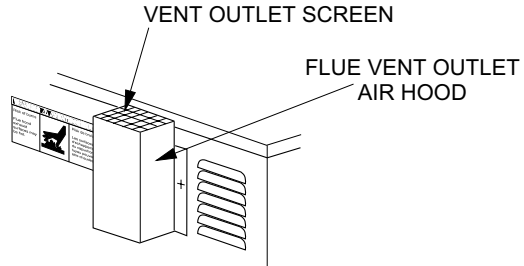
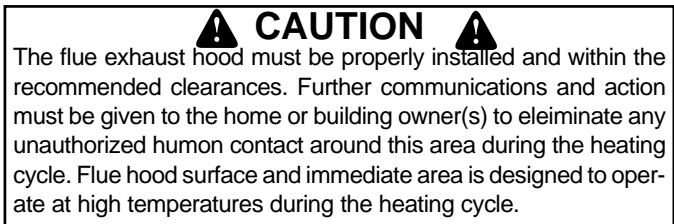

FIG. 3 - FLUE VENT OUTLET AIR HOOD



must be installed to assure proper unit operation. The hood must be fastened to the outside of the side gas control/electrical compartment with the screws provided in the bag attached to the inside of the gas control/electrical compartment, see Figure 3.

TABLE 6 - PHYSICAL DATA

MODELS		DYA						
		018	024	030	036	042	048	060
EVAPORATOR BLOWER	CENTRIFUGAL BLOWER (Dia. x Wd. in.)	10 X 8	10 X 8	10 X 8	11 x 10	11 x 10	12 x 11	12 x 11
	FAN MOTOR HP (Three Speed)	1/2	1/2	1/2	3/4	3/4	1.0	1.0
EVAPORATOR COIL	ROWS DEEP	2	2	2	2	3	3	3
	FINS PER INCH	14	13	13	15	13	13	13
	FACE AREA (Sq. Ft.)	2.25	3.5	3.5	3.5	3.5	4.5	4.5
CONDENSER FAN	PROPELLER DIA. (in.)	22	22	22	22	22	22	22
	FAN MOTOR HP	1/4	1/4	1/4	1/4	1/4	1/4	1/4
	NOM. CFM TOTAL	1,800	2,200	2,400	2,400	2,400	3,000	3,000
CONDENSER COIL	ROWS DEEP	1	1	1	1	1	1	1
	FINS PER INCH	13	13	16	20	20	20	20
	FACE AREA (Sq. Ft.)	8.3	8.3	11.7	11.7	11.7	14.8	14.8
CHARGE	REFRIGERANT 22 (lbs./oz.)	3 / 2	3 / 6	4 / 12	4 / 3	4 / 12	6 / 0	5 / 4
FILTER*	FACE AREA (Sq. Ft.) / SIZE (NOMINAL)	2.6/20x20	2.6/20x20	2.6/20x20	2.6/20x20	2.6/20x20	3.3/20x12	3.3/20x12
FURNACE SECTION	NATURAL GAS BURNER ORIFICE NO. (Qty./Drill size)	43	43	43	43	43	40	40
	PROPANE BURNER ORIFICE NO. (Qty./Drill size)	55	55	55	55	55	53	53
	GAS CONNECTION SIZE	1/2 NPTI	1/2 NPTI	1/2 NPTI	1/2 NPTI	1/2 NPTI	1/2 NPTI	1/2 NPTI
COMPRESSOR TYPE	HERMETICALLY SEALED (R = RECIPROCATING, S = Scroll)	R	R	R	R	R	S	S

* = Three phase 018 thru 042 size units are supplied with one (1) filter and on three phase 048 and 060 size units two (2) filters are supplied. Single phase units are shipped without filters. See "FILTERS" on page 4.

TABLE 7 - UNIT WEIGHTS

MODEL DYA	UNIT SHIPPING WEIGHT (lbs.)	UNIT OPERATING WEIGHT (lbs.)	CORNER OPERATING WEIGHTS (lbs., location, see Figure 4)			
			"A"	"B"	"C"	"D"
018	365	360	91	88	89	92
024	365	360	91	88	89	92
030	395	390	98	95	96	99
036	400	395	100	96	98	101
042	405	410	104	100	101	105
048	475	470	119	115	116	120
060	480	475	120	116	117	122

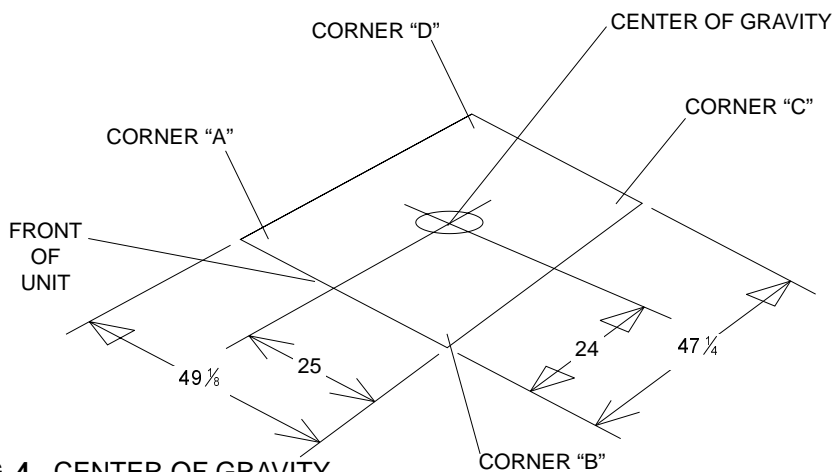
**FIG. 4 - CENTER OF GRAVITY****TABLE 8 - ELECTRICAL DATA**

MODEL DYA	POWER SUP- PLY	VOLTAGE LIMITATIONS ¹		COMPRESSOR		COND. FAN MOTOR, FLA	SUPPLY AIR BLOWER MOTOR, FLA	MINIMUM CIRCUIT AMPACITY	MAX. FUSE SIZE, AMPS ²	MAX. HACR BREAKER SIZE, AMPS	UNIT POWER FACTOR	TRANSFORMER SIZE ³ (VA)
		MIN.	MAX.	RLA	LRA							
018	208/230-1-60	187	253	9.0	48.0	1.1	2.2	14.5	20	20	.96	40
024	208/230-1-60	187	253	11.5	60.0	1.1	2.2	17.7	25	25	.96	40
030	208/230-1-60	187	253	14.7	73.0	1.1	2.2	21.7	30	30	.96	40
036	208/230-1-60	187	253	17.3	94.0	1.1	3.5	26.2	35	35	.96	40
042	208/230-1-60	187	253	20.5	120.0	1.1	3.5	30.2	40	40	.96	40
048	208/230-1-60	187	253	24.4	140.0	1.3	7.0	38.8	50	50	.96	40
060	208/230-1-60	187	253	28.9	175.0	1.3	7.0	44.4	60	60	.96	40
036	208/230-3-60	187	253	10.9	78.0	1.1	3.5	18.2	25	25	.96	75
042	208/230-3-60	187	253	14.1	110.0	1.1	3.5	22.2	30	30	.96	75
048	208/230-3-60	187	253	14.1	105	1.3	7.0	25.9	35	35	.96	75
060	208/230-3-60	187	253	15.5	125	1.3	7.0	29.5	40	40	.96	75
036	460-3-60	414	504	5.8	40.0	0.6	1.8	9.6	15	15	.96	75
042	460-3-60	414	504	7.1	54.0	0.6	1.8	11.2	15	15	.96	75
048	460-3-60	414	504	7.1	55.0	0.7	3.5	13.1	20	20	.96	75
060	460-3-60	414	504	8.9	66.5	0.7	3.5	15.4	20	20	.96	75
036	575-3-60	518	630	4.5	32.0	0.4	1.5	7.5	15	15	.96	75
042	575-3-60	518	630	5.8	44.0	0.4	1.5	9.1	15	15	.96	75
048	575-3-60	518	630	5.7	45.0	0.6	2.8	10.5	15	15	.96	75
060	575-3-60	518	630	7.1	50.0	0.6	2.8	12.3	15	15	.96	75

Note: Electrical data based on 104°F outdoor air ambient temperature.

¹ = Utilization Range "A" in accordance with ARI Standard 110. ² = Dual element, time delay type.

³ = If economizer or motorized damper are to be used, 75 VA is required. Refer to price pages for future details.

UNIT SIZE	DIMENSION	
	"A"	"B"
018 THRU 042	33 1/2	18 1/4
048 AND 060	41 1/2	23 3/8

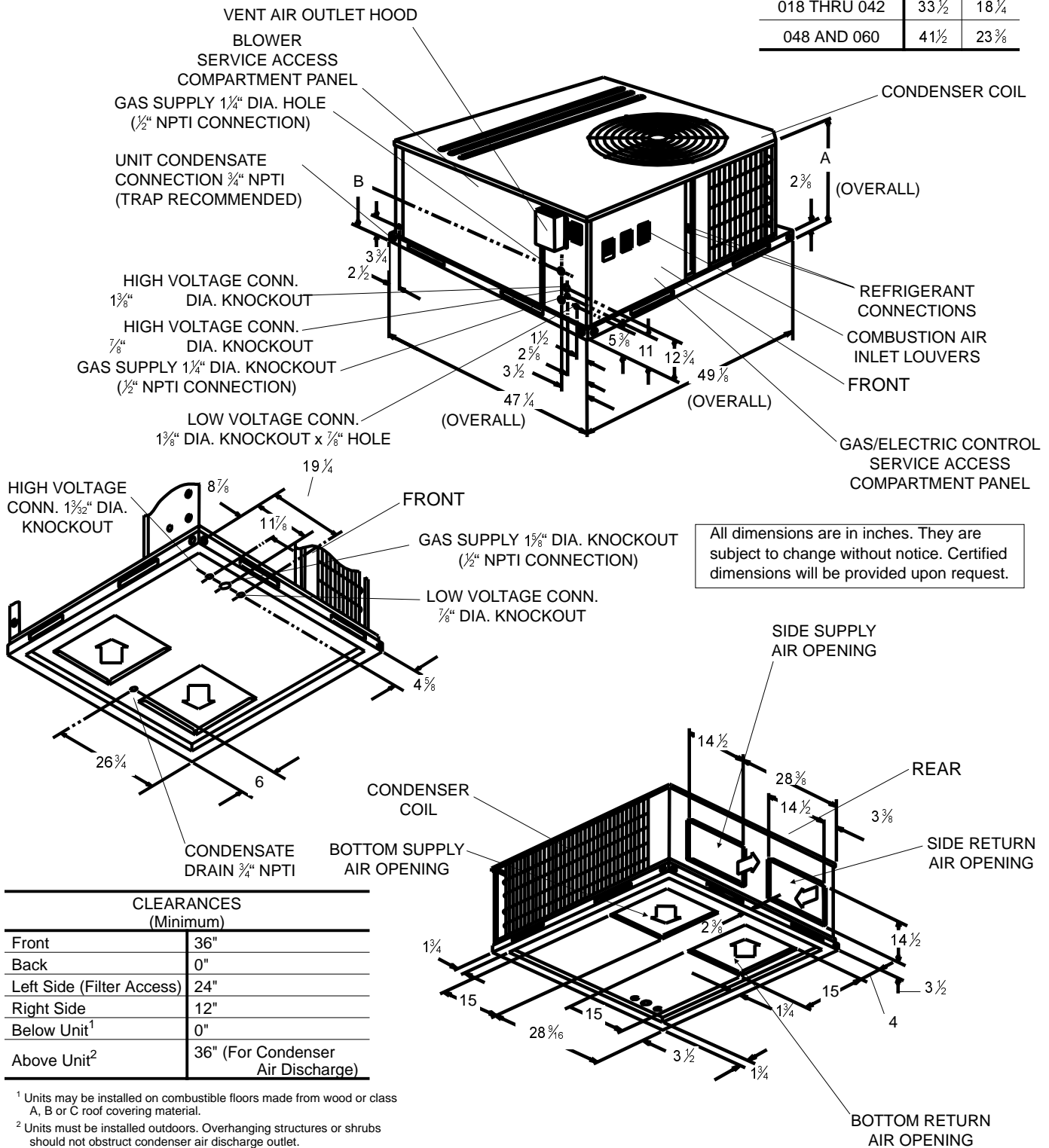

FIG. 5 - DIMENSIONS AND CLEARANCES

SEQUENCE OF OPERATION

The unit is controlled by a conventional four wire heating/cooling thermostat common to this class of equipment.

HEATING

When the thermostat calls for "HEAT", the thermostat terminal "W" is energized, energizing the combustion air blower.

After airflow is established, the air proving switch closes, the hot surface ignitor is energized and the pilot valve opens igniting the pilot flame. The system will try to light the pilot for 90 seconds. After 90 seconds, the pilot valve will close and the system will retry in 5 minutes.

The flame rod senses a flame and de-energizes the ignitor opening the main gas valve and the main burners light.

30 seconds after the main burners light the circulating fan is energized at the heating speed.

When the thermostat is satisfied, terminal "W" is de-energized, de-energizing the ignition system closing the gas valve.

After a 5 second postpurge timing period, the combustion air blower is de-energized and the heat fan off timing begins.

When this field selected heat fan off timing is completed the circulating fan is de-energized.

If the primary, rollout or auxiliary limit switches open, the thermostat and ignition system is de-energized and the gas valve closes. The combustion blower and the circulating fan, at heat speed, are energized.

The combustion blower remains energized for the 5 second postpurge timing period if the primary, rollout or auxiliary limit

switches remake the contact (the rollout and auxiliary limit switches must be manually reset). The circulating fan remains energized for the selected heat delay off timing.

Normal operation of the system resumes.

COOLING

When the thermostat calls for "COOL", the thermostat terminals "G" and "Y" are energized signaling the compressor and outdoor fan to run.

After a cool fan on delay timing of 2 seconds, the circulating fan is energized at cooling speed.

When the thermostat is satisfied, terminals "G" and "Y" are de-energized, de-energizing the compressor and outdoor fan.

After a cool fan off delay timing of 30 seconds the circulating fan is de-energized.

CIRCULATING FAN

When the thermostat calls for "FAN", the thermostat terminal "G" is energized signaling the circulating fan to run at the heat speed 2 seconds after the "G" terminal is energized.

If a call for "HEAT" occurs, the circulating fan continues to run at the heat speed.

If a call for "COOL" occurs, the circulating fan switches to cool speed after a 4 second delay.

When the thermostat ends the call for "FAN", the thermostat terminal "G" is de-energized, de-energizing the circulating fan.

START-UP

PRE-START CHECK LIST

Complete the following checks before starting the unit.

1. Check the type of gas being supplied. Be sure that it is the same as listed on the unit nameplate.
2. Make sure that the vent outlet air hoods has been properly installed.

OPERATING INSTRUCTIONS

1. STOP! Read the information on the unit safety label.
2. Set the thermostat to the "OFF" position.
3. Turn off all electrical power to the unit.
4. DO NOT try to light the burners by hand. This appliance is equipped with an ignition device which automatically lights the burners.
5. Remove the access panel.
6. Turn the gas valve switch to the "OFF" position.
7. Wait five (5) minutes to clear out any gas. If you then smell gas, **STOP!** Follow "B" in the information on the unit safety label. If you don't smell gas, go to the next step.

8. Turn the gas valve switch to the "ON" position.
9. Replace the control access panel.
10. Turn on all electric power to the unit.
11. Set the thermostat to the desired setting.
12. If the unit will not operate, follow the instructions "To Turn Off Gas To Appliance" and call your service technician or gas supplier.

TO TURN OFF GAS TO UNIT

1. Set the thermostat to the "OFF" position.
2. Turn off all electric power to the appliance if service is to be performed.
3. Remove the control access panel.
4. Turn the gas valve switch to the "OFF" position. **DO NOT FORCE.**
5. Replace the control access panel.

POST-START CHECK LIST (GAS)

After the entire control circuit has been energized and the heating section is operating, make the following checks:

1. Check for gas leaks in the unit piping as well as the supply piping.

2. Check for correct manifold gas pressures. See "Checking Gas Input".
3. Check the supply gas pressure. It must be within the limits shown on rating nameplate. Supply pressure should be checked with all gas appliances in the building at full fire. At no time should the standby gas line pressure exceed 10.5", nor the operating pressure drop below 4.5" for natural gas units. If gas pressure is outside these limits, contact the local gas utility for corrective action.

MANIFOLD GAS PRESSURE ADJUSTMENT

Small adjustments to the gas flow may be made by turning the pressure regulator adjusting screw on the automatic gas valve. Refer to Figure 6.

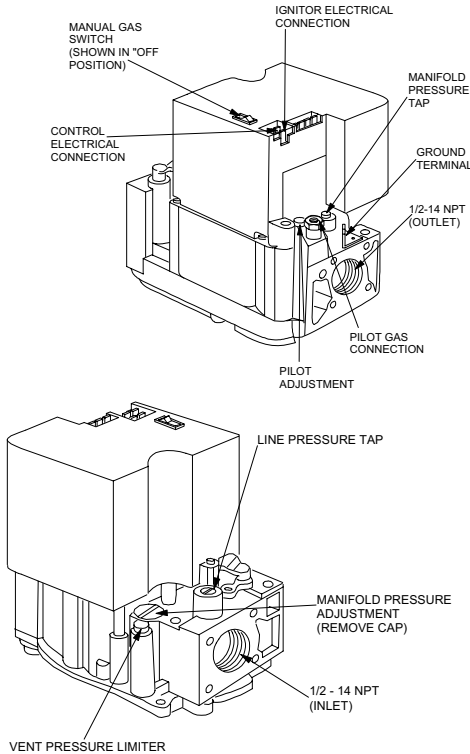

FIG. 6 - GAS VALVE

Adjust as follows:

1. Remove the cap from the valve body. See Figure 6 for location.
2. To decrease the gas pressure, turn the adjusting screw counterclockwise.
3. To increase the gas pressure, turn the adjusting screw clockwise.

NOTE: The correct manifold pressure for natural gas furnaces is 3.5 IWG ±0.2. The correct manifold pressure for propane (LP) is 10.0 IWG ±0.2.

BURNER INSTRUCTIONS

To check or change the burners, CLOSE THE MAIN MANUAL SHUT-OFF VALVE AND SHUT OFF ALL POWER TO THE UNIT.

1. Remove the two (2) #8 screws holding each burner in place.

2. Remove the burner assembly from the manifold assembly by moving the burner assembly forward, turn at an angle and pull back.
3. Burners are now accessible for service.

HOT SURFACE PILOT INSTRUCTIONS

To check, adjust or remove the hot surface pilot assembly, CLOSE THE MAIN MANUAL SHUT-OFF VALVE AND SHUT OFF ALL POWER TO THE UNIT.

The pilot flame should envelope 3/8 inch of the end of the flame sensor and not contain any yellow color, see Figure 7.

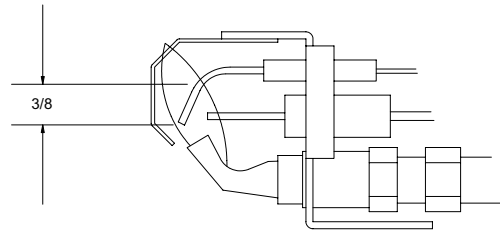

FIG. 7 - PROPER FLAME ADJUSTMENT

To adjust the pilot flame:

1. Remove the pilot adjustment cover screw.
2. Adjust the pilot adjustment screw to achieve the proper pilot flame.
3. Replace the pilot adjustment cover screw after the pilot flame is set.

To remove the hot surface pilot assembly:

1. Disconnect the wiring from the gas valve to the hot surface pilot assembly.
2. Remove the two (2) #8 screws holding the hot surface pilot assembly in place.
3. Remove the hot surface pilot assembly.

To remove the hot surface ignitor and flame sensor assembly:

1. Remove the clip attaching the ignitor and sensor assembly as shown in Figure 8.

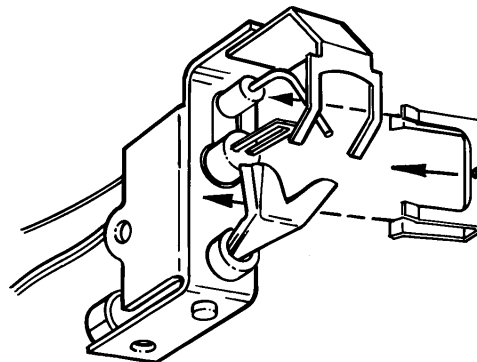

FIG. 8 - IGNITOR AND FLAME SENSOR ASSEMBLY

2. Lift the pilot and sensor from the assembly. Care must be taken not to damage the pilot or sensor when removing this assembly.

- After maintenance of the pilot assembly, always measure the resistance across the ignitor. If the resistance is greater than 10 ohms, discard the ignitor and replace it with a new ignitor.

ADJUSTMENT OF TEMPERATURE RISE

$$\text{°F Temp. Rise} = \frac{\text{BTUH Output}}{1.08 \times \text{CFM}} \quad (\text{OR}) \quad \text{CFM} = \frac{\text{BTUH Output}}{1.08 \times \text{°F Temp. Rise}}$$

The temperature rise (or temperature difference between the return air and the heated air from the furnace) must lie within the range shown on the rating plate and the data in Tables 2 and 3.

After the temperature rise has been determined, the CFM can be calculated as follows:

After about 20 minutes of operation, determine the furnace temperature rise. Take readings of both the return air and the heated air in the ducts about six feet from the furnace where they will not be affected by radiant heat. Increase the blower CFM to decrease the temperature rise; decrease the blower CFM to increase the rise.

DIRECT DRIVE BLOWER

All units have direct drive multi-speed blower motors. Refer to the unit wiring diagram and connect the blower motor for the desired CFM.

CHECKING GAS INPUT

NATURAL GAS

- Turn off all other gas appliances connected to the gas meter.
- With the furnace turned on, measure the time needed for one revolution of the hand on the smallest dial on the meter. A typical gas meter usually has a 1/2 or a 1 cubic foot test dial.
- Using the number of seconds for each revolution and the size of the test dial increment, find the cubic feet of gas consumed per hour from Table 9.

If the actual input is not within 5% of the furnace rating with allowance being made for the permissible range of the regulator setting, replace the orifice spuds with spuds of the proper size.

NOTE: To find the BTU input, multiply the number of cubic feet of gas consumed per hour by the BTU content of the gas in your particular locality. (Contact your gas company for this information since it varies widely from city to city.)

SECURE OWNER'S APPROVAL

When the system is functioning properly, secure the owner's approval. Show him the location of all disconnect switches and the thermostat. Teach him how to start and stop the unit and how to adjust temperature settings within the limitations of the system. Advise him that the flue exhaust hood surface and the immediate area will experience high temperatures during the heating cycle. All unauthorized personnel and debris must be kept away from this area.

TABLE 9 - GAS RATE- CUBIC FEET PER HOUR

Seconds for One Rev.	Size of Test Dial	
	1/2 cu. ft.	1 cu. ft.
10	180	360
12	150	300
14	129	257
16	113	225
18	100	200
20	90	180
22	82	164
24	75	150
26	69	138
28	64	129
30	60	120
32	56	113
34	53	106
36	50	100
38	47	95
40	45	90
42	43	86
44	41	82
46	39	78
48	37	75
50	36	72
52	35	69
54	34	67
56	32	64
58	31	62
60	30	60

Example: By actual measurement, it takes 38 seconds for the hand on the 1-cubic foot dial to make a revolution with just a 100,000 BTUH furnace running. Using this information, locate 38 seconds in the first column of Table 9. Read across to the column headed "1 Cubic Foot," where you will see that 95 cubic feet of gas per hour are consumed by the furnace at that rate. Multiply 95 x 1050 (the BTU rating of the gas obtained from the local gas company). The result is 99,750 BTUH, which is close to the 100,000 BTUH rating of the furnace.

MAINTENANCE

NORMAL MAINTENANCE

WARNING: Prior to any of the following maintenance procedures, shut off all power to the unit, to avoid personal injury.

Periodic maintenance consists of changing or cleaning filters. Under some conditions, the main burners should be cleaned.

FILTERS - Inspect once a month. Replace Disposable or clean Permanent Type as necessary. DO NOT replace Permanent Type with Disposable.

MOTORS - Indoor and outdoor fan motors, along with the combustion blower are permanently lubricated and require no maintenance.

OUTDOOR COIL - Dirt should not be allowed to accumulate on the outdoor coil surface or other parts in the air circuit. Cleaning should be as often as necessary to keep the coil clean. Use a brush, vacuum cleaner attachment, or other suitable means. If water is used to clean the coil, be sure that the power to the unit is shut off prior to cleaning.

CAUTION: Exercise care when cleaning the coil so that the coil fins are not damaged.

Do not permit the hot condenser air discharge to be obstructed by overhanging structures or shrubs.

BURNER - At the beginning of each heating season, make a visual check of the main burner flame. If it is not possible to adjust for the proper flame, the burners may need cleaning.

TO CLEAN BURNERS - Remove them from the furnace as explained in "Burner Instructions". Clean burners with hot water applied along top of the burner.

COMBUSTION AIR DISCHARGE - Visually inspect discharge outlet periodically to insure soot and dirt buildup is not excessive. If necessary, clean to maintain adequate combustion air discharge.

The manufacture recommends that the furnace system be inspected once a year by a qualified service person.

CLEANING FLUE PASSAGES AND HEATING ELEMENTS

With proper combustion adjustment the heating element of a gas fired furnace will seldom need cleaning. If the element should become sooted, it can be cleaned as follows:

1. Remove the burner assembly as outlined in "BURNER INSTRUCTIONS".
2. Remove the screws securing the restrictor plate to the tube sheet.
3. Using a wire brush on a flexible wand, brush out the inside of each heat exchanger from the burner inlet and flue outlet ends.
4. Brush out the inside of the restrictor plate to the tube sheet.
5. If soot build-up is particularly bad, remove the vent motor and clean the wheel and housing.
6. After brushing is complete, blow all brushed areas with air or nitrogen. Vacuum as needed.
7. Replace parts in the order they were removed in steps 1 thru 3.

TABLE 10 - SUPERHEAT CHARGING TABLE FOR MODEL D1YA018

OUTDOOR TEMPERATURE (F)	SUPERHEAT AT COMPRESSOR SUCTION (F), AIRFLOW = 400 CFM/TON										
	INDOOR WB TEMPERATURE (F)										
	55	57	59	61	63	65	67	69	71	73	75
65	17.1	19.5	21.9	24.4	26.8	29.3	31.7	32.7	33.7	34.6	35.6
70	13.6	16.2	18.8	21.5	24.1	26.8	29.4	30.6	31.8	33.1	34.3
75	10.1	12.9	15.7	18.6	21.4	24.3	27.1	28.6	30.0	31.5	32.9
80	6.6	9.6	12.7	15.7	18.7	21.8	24.8	26.5	28.2	29.9	31.6
85	-	6.3	9.6	12.8	16.0	19.3	22.5	24.4	26.4	28.3	30.2
90	-	-	6.8	9.9	13.0	16.1	19.3	21.6	24.0	26.4	28.8
95	-	-	-	7.1	10.0	13.0	16.0	18.8	21.7	24.5	27.4
100	-	-	-	-	7.1	9.6	12.0	15.4	18.8	22.3	25.7
105	-	-	-	-	-	6.1	8.0	12.0	16.0	20.0	24.0
110	-	-	-	-	-	-	-	8.6	13.1	17.7	22.2
115	-	-	-	-	-	-	-	5.1	10.3	15.4	20.5

TABLE 11 - SUPERHEAT CHARGING TABLE FOR MODEL D1YA024

OUTDOOR TEMPERATURE (F)	SUPERHEAT AT COMPRESSOR SUCTION (F), AIRFLOW = 400 CFM/TON										
	INDOOR WB TEMPERATURE (F)										
	55	57	59	61	63	65	67	69	71	73	75
65	13.9	16.5	19.0	21.5	24.1	26.6	29.2	29.7	30.3	30.9	31.5
70	9.5	12.5	15.5	18.5	21.5	24.5	27.5	28.2	28.8	29.4	30.1
75	5.2	8.6	12.1	15.5	19.0	22.4	25.9	26.6	27.3	28.0	28.7
80	-	-	8.7	12.5	16.4	20.3	24.2	25.0	25.8	26.5	27.3
85	-	-	5.2	9.6	13.9	18.3	22.6	23.4	24.2	25.1	25.9
90	-	-	-	7.8	11.9	16.1	20.3	21.5	22.7	23.8	25.0
95	-	-	-	6.0	10.0	14.0	18.0	19.5	21.1	22.6	24.2
100	-	-	-	-	8.4	12.1	15.9	17.7	19.5	21.3	23.1
105	-	-	-	-	6.9	10.3	13.8	15.8	17.9	20.0	22.0
110	-	-	-	-	5.3	8.5	11.7	14.0	16.3	18.7	21.0
115	-	-	-	-	-	6.7	9.6	12.2	14.8	17.3	19.9

TABLE 12 - SUPERHEAT CHARGING TABLE FOR MODEL D1YA030

OUTDOOR TEMPERATURE (F)	SUPERHEAT AT COMPRESSOR SUCTION (F), AIRFLOW = 400 CFM/TON										
	INDOOR WB TEMPERATURE (F)										
	55	57	59	61	63	65	67	69	71	73	75
65	13.7	16.9	20.1	23.3	26.6	29.8	33.0	33.5	34.0	34.5	35.0
70	10.8	14.2	17.7	21.1	24.5	28.0	31.4	32.1	32.8	33.5	34.2
75	7.8	11.5	15.2	18.8	22.5	26.2	29.8	30.7	31.6	32.6	33.5
80	-	8.8	12.7	16.6	20.5	24.4	28.2	29.4	30.5	31.6	32.7
85	-	6.1	10.2	14.3	18.4	22.6	26.7	28.0	29.3	30.6	32.0
90	-	-	7.3	11.5	15.7	19.9	24.1	25.9	27.7	29.5	31.3
95	-	-	-	8.6	13.0	17.3	21.6	23.8	26.1	28.3	30.6
100	-	-	-	6.9	10.7	14.5	18.3	21.2	24.0	26.9	29.7
105	-	-	-	5.1	8.4	11.8	15.1	18.5	22.0	25.4	28.9
110	-	-	-	-	6.2	9.0	11.8	15.9	19.9	24.0	28.0
115	-	-	-	-	-	6.2	8.5	13.2	17.9	22.5	27.2

TABLE 13 - SUPERHEAT CHARGING TABLE FOR MODEL D1YA036

OUTDOOR TEMPERATURE (F)	SUPERHEAT AT COMPRESSOR SUCTION (F), AIRFLOW = 400 CFM/TON										
	INDOOR WB TEMPERATURE (F)										
	55	57	59	61	63	65	67	69	71	73	75
65	27.1	28.4	29.7	31.1	32.4	33.7	35.0	35.9	36.8	37.6	38.5
70	23.3	24.8	26.2	27.7	29.2	30.6	32.1	33.5	34.9	36.4	37.8
75	19.5	21.1	22.7	24.4	26.0	27.6	29.2	31.2	33.1	35.1	37.1
80	15.7	17.5	19.2	21.0	22.8	24.5	26.3	28.8	31.3	33.8	36.3
85	11.9	13.8	15.7	17.6	19.6	21.5	23.4	26.5	29.5	32.6	35.6
90	8.6	10.6	12.6	14.6	16.6	18.6	20.6	24.1	27.6	31.1	34.6
95	5.3	7.4	9.5	11.5	13.6	15.7	17.8	21.7	25.7	29.7	33.7
100	-	5.6	7.6	9.6	11.6	13.6	15.6	20.1	24.5	28.9	33.4
105	-	-	5.7	7.6	9.6	11.5	13.5	18.4	23.3	28.2	33.1
110	-	-	-	5.6	7.5	9.4	11.3	16.7	22.1	27.4	32.8
115	-	-	-	-	5.5	7.4	9.2	15.0	20.9	26.7	32.5

TABLE 14 - SUPERHEAT CHARGING TABLE FOR MODEL D1YA042

OUTDOOR TEMPERATURE (F)	SUPERHEAT AT COMPRESSOR SUCTION (F), AIRFLOW = 400 CFM/TON										
	INDOOR WB TEMPERATURE (F)										
	55	57	59	61	63	65	67	69	71	73	75
65	18.0	19.7	21.4	23.0	24.7	26.3	28.0	29.1	30.2	31.3	32.4
70	13.4	15.3	17.3	19.3	21.2	23.2	25.2	26.6	28.1	29.6	31.1
75	8.7	10.9	13.2	15.5	17.8	20.0	22.3	24.2	26.1	28.0	29.9
80	-	6.6	9.1	11.7	14.3	16.9	19.5	21.7	24.0	26.3	28.6
85	-	-	5.1	7.9	10.8	13.7	16.6	19.3	21.9	24.6	27.3
90	-	-	-	6.7	9.3	11.9	14.6	17.4	20.2	23.1	25.9
95	-	-	-	5.5	7.8	10.2	12.5	15.5	18.5	21.5	24.5
100	-	-	-	-	6.3	8.0	9.8	12.9	16.1	19.2	22.4
105	-	-	-	-	-	5.9	7.1	10.3	13.7	16.9	20.3
110	-	-	-	-	-	-	-	7.8	11.2	14.7	18.1
115	-	-	-	-	-	-	-	5.2	8.8	12.4	16.0

TABLE 15 - SUPERHEAT CHARGING TABLE FOR MODEL D1YA048

OUTDOOR TEMPERATURE (F)	SUPERHEAT AT COMPRESSOR SUCTION (F), AIRFLOW = 400 CFM/TON										
	INDOOR WB TEMPERATURE (F)										
	55	57	59	61	63	65	67	69	71	73	75
65	20.9	21.8	22.7	23.6	24.4	25.3	26.2	27.4	28.6	29.8	31.0
70	17.6	18.7	19.7	20.7	21.7	22.7	23.7	25.2	26.6	28.1	29.6
75	14.4	15.5	16.6	17.8	18.9	20.0	21.2	22.9	24.7	26.4	28.2
80	11.1	12.4	13.6	14.9	16.1	17.4	18.6	20.7	22.7	24.8	26.8
85	7.8	9.2	10.6	12.0	13.3	14.7	16.1	18.4	20.8	23.1	25.4
90	5.8	7.0	8.2	9.3	10.5	11.7	12.9	15.7	18.6	21.5	24.4
95	-	-	5.8	6.7	7.7	8.6	9.6	13.0	16.5	19.9	23.3
100	-	-	5.4	6.0	6.7	7.4	8.0	11.6	15.2	18.7	22.3
105	-	-	-	5.3	5.7	6.1	6.5	10.2	13.9	17.6	21.3
110	-	-	-	-	-	-	-	8.7	12.6	16.4	20.3
115	-	-	-	-	-	-	-	7.3	11.3	15.3	19.3

TABLE 16 - SUPERHEAT CHARGING TABLE FOR MODEL DBYA060

OUTDOOR TEMPERATURE (F)	SUPERHEAT AT COMPRESSOR SUCTION (F), AIRFLOW = 400 CFM/TON										
	INDOOR WB TEMPERATURE (F)										
	55	57	59	61	63	65	67	69	71	73	75
65	7.0	9.2	11.4	13.6	15.9	18.1	20.3	21.8	23.2	24.7	26.1
70	6.1	8.4	10.7	13.0	15.2	17.5	19.8	21.2	22.7	24.1	25.6
75	5.3	7.6	9.9	12.3	14.6	16.9	19.3	20.7	22.2	23.6	25.0
80	-	6.8	9.2	11.6	14.0	16.3	18.7	20.2	21.6	23.1	24.5
85	-	6.0	8.4	10.9	13.3	15.8	18.2	19.6	21.1	22.5	23.9
90	-	-	6.5	8.7	10.8	12.9	15.1	17.1	19.1	21.1	23.1
95	-	-	-	6.5	8.3	10.1	11.9	14.5	17.1	19.7	22.3
100	-	-	-	5.9	7.3	8.6	10.0	12.9	15.8	18.7	21.6
105	-	-	-	5.3	6.2	7.1	8.0	11.3	14.5	17.7	20.9
110	-	-	-	-	5.2	5.6	6.1	9.6	13.2	16.7	20.2
115	-	-	-	-	-	-	-	8.0	11.8	15.7	19.6

TROUBLESHOOTING

NOTE: Before troubleshooting, familiarize yourself with the startup and checkout procedure.

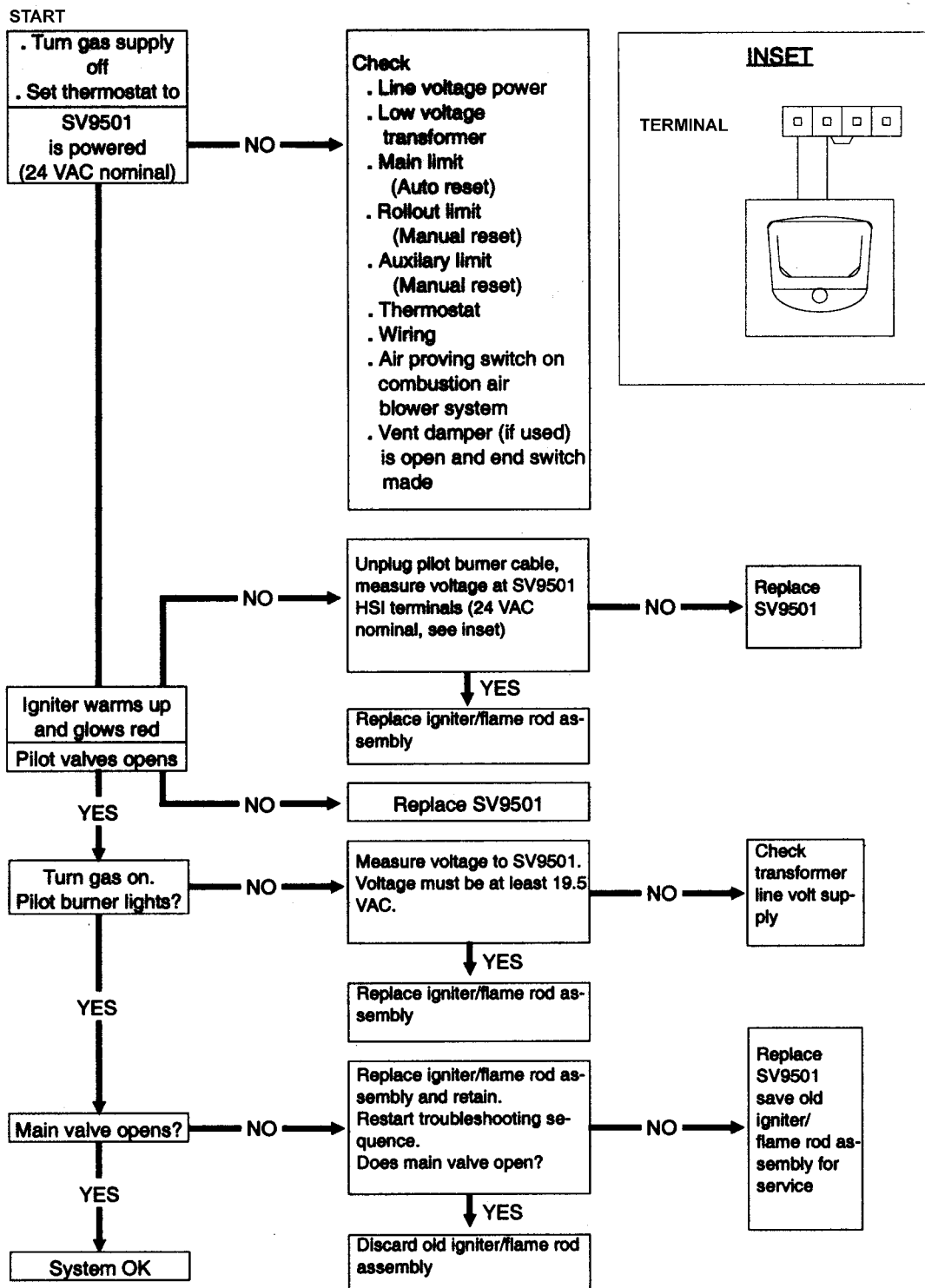

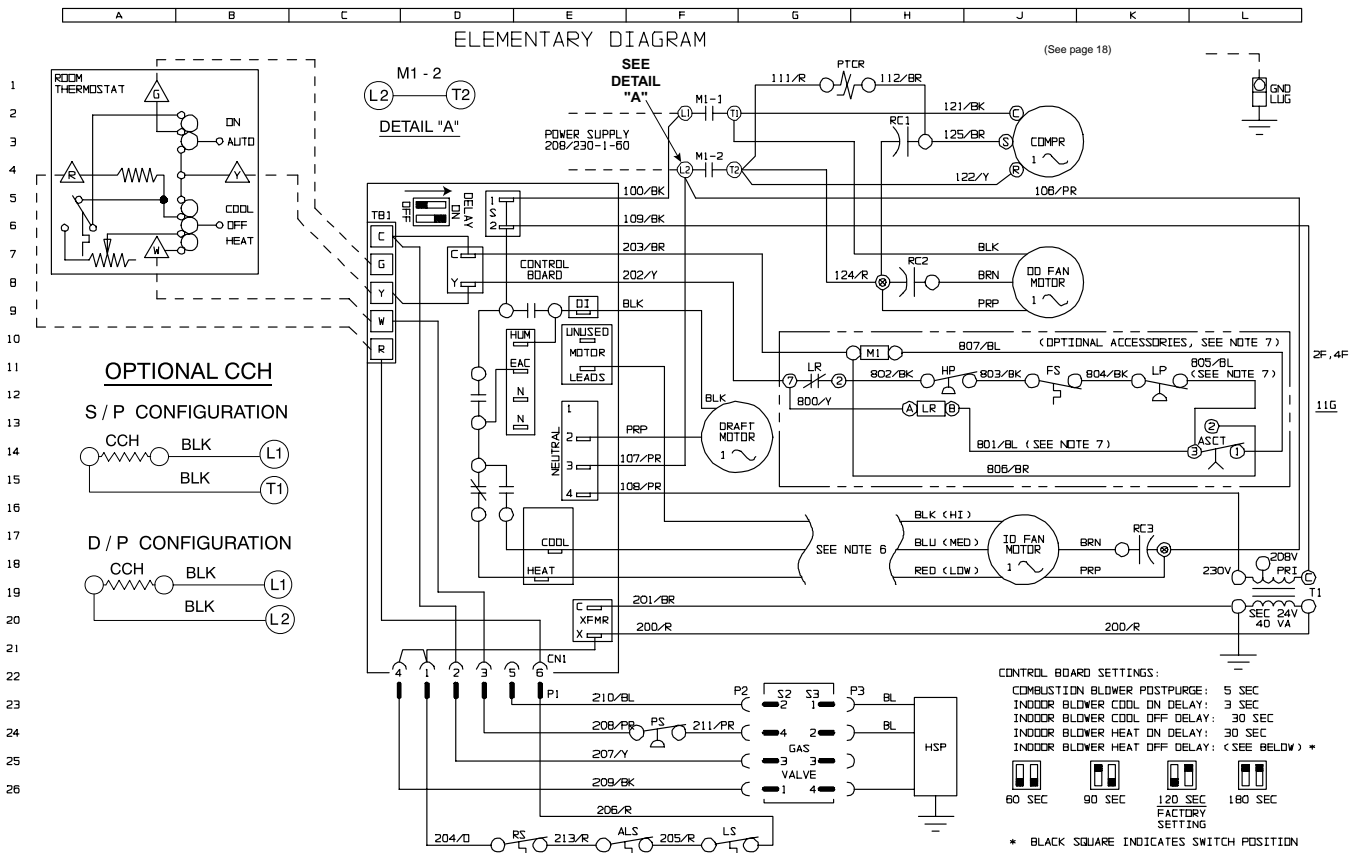

FIG. 9 - TYPICAL WIRING DIAGRAM (208/230-1-60 POWER SUPPLY)

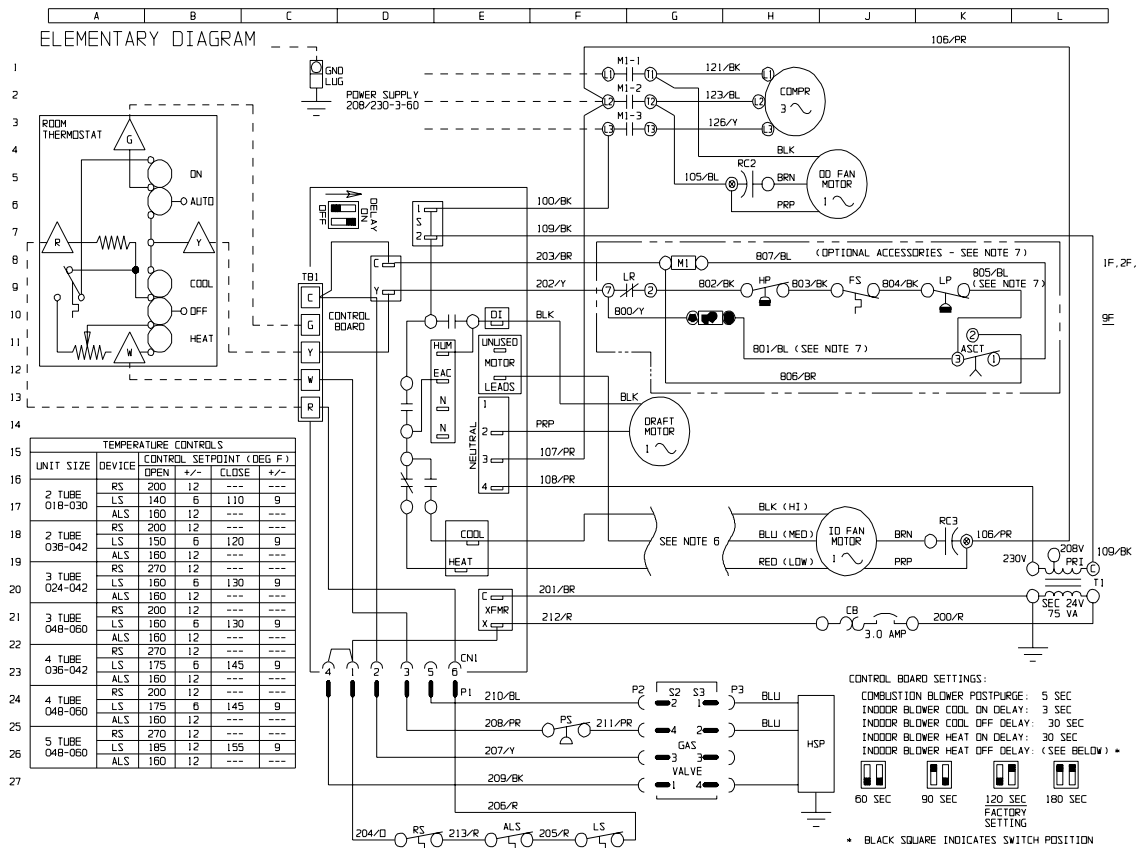

FIG. 10 - TYPICAL WIRING DIAGRAM (208/230-3-60 POWER SUPPLY)

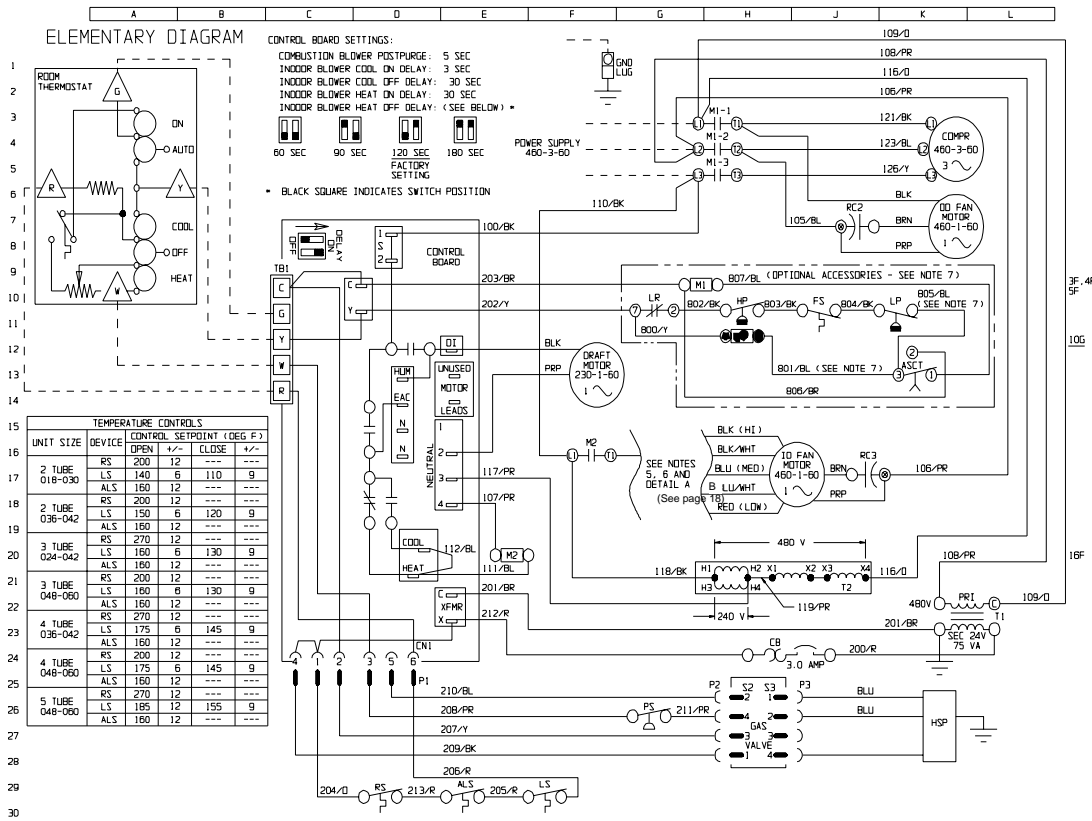

FIG. 11 - TYPICAL WIRING DIAGRAM (460-3-60 POWER SUPPLY)

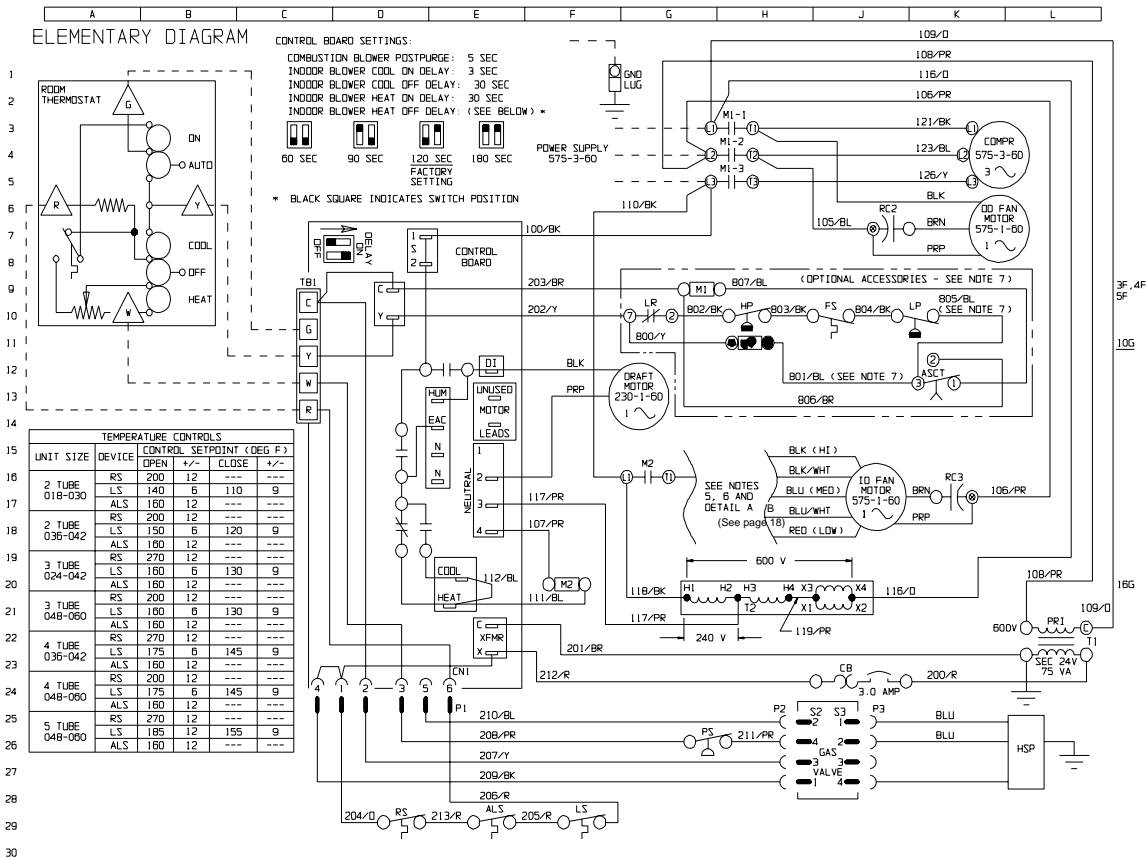

FIG. 12 - TYPICAL WIRING DIAGRAM (575-3-60 POWER SUPPLY)

TYPICAL WIRING DIAGRAM NOTES (See pages 16 and 17)

1. ALL FIELD WIRING TO BE ACCOMPLISHED FOLLOWING CITY, LOCAL AND/OR NATIONAL CODES IN EFFECT AT TIME OF INSTALLATION OF THIS UNIT.
2. CAUTION: LABEL ALL WIRES PRIOR TO DISCONNECTION WHEN SERVICING CONTROLS. WIRING ERRORS CAN CAUSE IMPROPER AND DANGEROUS OPERATION. IF ANY OF THE WIRE AS SUPPLIED WITH THIS UNIT MUST BE REMOVED, IT MUST BE REPLACED WITH TYPE 105° C, 600V WIRE OR EQUIVALENT CLEARLY RENUMBERED FOR IDENTIFICATION. VERIFY PROPER OPERATION AFTER SERVICING.
3. MOTORS ARE INHERENTLY PROTECTED.
4. SEE UNIT NAMEPLATE FOR MAXIMUM FUSE SIZE AND MINIMUM CIRCUIT AMPACITY.
5. UNIT FACTORY WIRE FOR LOW OR MEDIUM SPEED INDOOR BLOWER OPERATION. TO CHANGE MOTOR SPEED, CONNECT SPEED TAP WIRES FROM INDOOR BLOWER MOTOR PER DETAIL B. TAPE UNUSED SPEED TAP WIRES TO PREVENT SHORTING AND SECURE NEAR M2 CONTACTOR.
6. SELECT INDOOR BLOWER SPEED TO REMAIN WITHIN THE TEMPERATURE RISE RANGE ON THE NAMEPLATE IN HEATING AND TO OBTAIN APPROX 400 CFM/TON IN COOLING.
7. IF BOTH LR AND ASCT ARE PRESENT, WIRE 801/BL AND 805/BL ARE CONNECTED TO ASCT-3. IF LR ONLY IS PRESENT, WIRE 801/BL AND 805/BL ARE CONNECTED TO M1 COIL. IF ASCT ONLY IS PRESENT WIRE 202/Y IS CONNECTED TO ASCT-3. IF NEITHER LR OR ASCT ARE PRESENT, WIRE 202/Y IS CONNECTED TO M1 COIL.
8. SHUNT CONTACT ALSO USED WITH CRANKCASE HEATER. (OPTIONAL)

CAUTION - OPEN ALL DISCONNECTS
BEFORE SERVICING THIS UNIT

TYPICAL WIRING DIAGRAM LEGEND (See pages 16 and 17)

CCH	CRANKCASE HEATER (OPTIONAL)
M1	CONTACTOR, COMPRESSOR & OUTDOOR FAN
M2	CONTACTOR, INDOOR BLOWER MOTOR (230V COIL)
T2	TRANSFORMER, 240 VOLT, SECONDARY
T1	TRANSFORMER, 24 VOLT, SECONDARY
RC1/RC2	COMPRESSOR START & OUTDOOR FAN RUN CAPACITOR
RC1	COMPRESSOR START CAPACITOR (ALTERNATE)
RC2	OUTDOOR FAN RUN CAPACITOR (ALTERNATE)
RC3	INDOOR FAN RUN CAPACITOR
CB	CIRCUIT BREAKER, 3.0 AMP
COMP	COMPRESSOR
HSP	HOT SURFACE TO PILOT
LS	LIMIT SWITCH
ALS	AUXILIARY LIMIT SWITCH
PS	PRESSURE SWITCH - MAKES @ .193 IWC NOM (.33 IWC MAX)
RS	ROLLOUT SWITCH
HUM	HUMIDIFIER RELAY OUTPUT ON CONTROL BOARD, 208/230-1-60, 18VA MAX
EAC	ELECTRONIC AIR CLEANER RELAY OUTPUT ON CONTROL BOARD, 208/230-1-60, 18VA MAX
HP	HIGH PRESSURE SWITCH (OPTIONAL ACCESSORY)- OPEN @ 380 PSIG
FS	FREEZESTAT SWITCH (OPTIONAL ACCESSORY) OPEN @ 26°F
LP	LOW PRESSURE SWITCH (OPTIONAL ACCESSORY) OPEN @ 7 PSIG
LR	LOCK OUT RELAY (OPTIONAL ACCESSORY)
ASCT	ANTI-SHORT CYCLE TIMER (OPTIONAL ACCESSORY)
⊗	IDENTIFIED TERMINAL ON RUN CAPACITOR
△	ROOM THERMOSTAT 24V CONNECTIONS
□	TB1 ON CONTROL BOARD
—————	FACTORY WIRING AND DEVICES
-----	OPTIONAL WIRING AND DEVICES
-----	FIELD WIRING
CN1/P1	SOCKET/PLUG CONNECTION, 24V, 6 PIN ON CONTROL BOARD
S2/P2	SOCKET/PLUG CONNECTION, 24V, 4 PIN ON GAS VALVE
S3/P3	SOCKET/PLUG CONNECTION, 24V, 4 PIN ON GAS VALVE
S4/P4	SOCKET/PLUG CONNECTION, 230V, 2 PIN IN CONTROL BOX

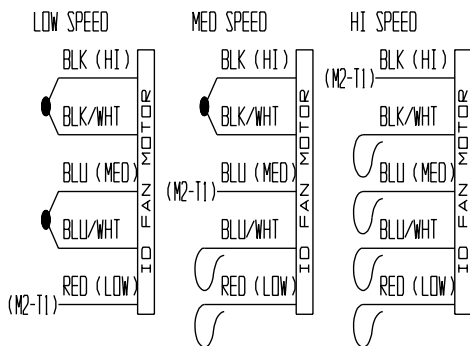

FIG. 13 - WIRING DIAGRAM DETAIL "B"
(460 & 575-3-60 POWER SUPPLY) See page 17

NOTES

